



Large Hose Cutting Work Center

Transfer Flow Incorporated

Mohsen Al-Mohammed

Julio Hernandez

Brett Karr

Kelly Womack

Dr. Webster Johnson

PROJECT OVERVIEW

The purpose of this project was to create a work center that cuts large diameter hose to alleviate inconsistencies and increase quality of hose cuts. This machine will also relieve employee hand fatigue that could lead to employee injury, and reduce debris that is caused by the current band saw cutting method.

The constraints of this project:

- The sponsor must be able to fabricate majority of parts in-house
- Must use MACH 3 G-code programming software
- Run off 110 AC and 95 psi

The objectives of the project include:

- Cut rubber hose without deformity
- Give a clean, smooth, and perpendicular cut
- Cut all 3/4" - 3" I.D. hose stock TFI implements
- Meet OSHA safety standards
- Quick and easy setup with no hardware changes

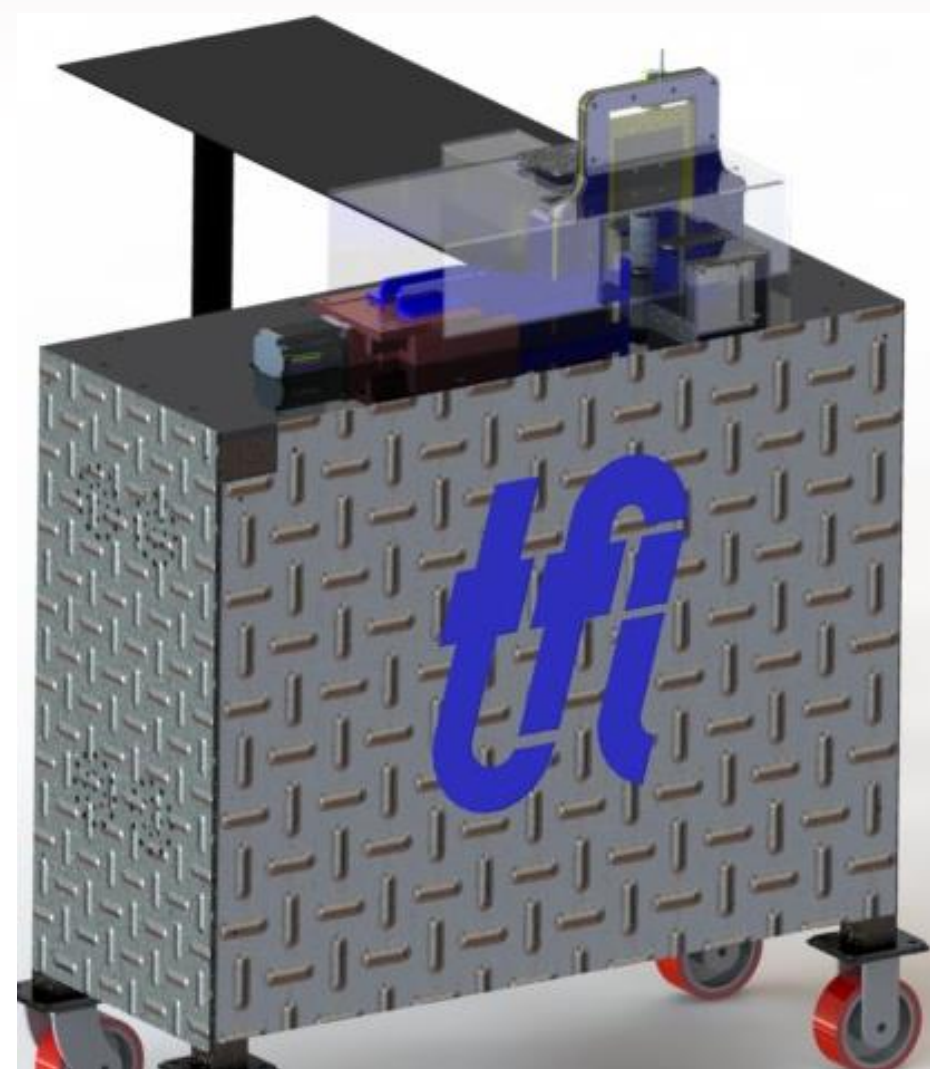

OSHA Safety Standards

To meet with OSHA standard 1910.220 the Large Hose Cutting Machine has an acrylic protective case surrounding the moving parts on top, This restricts the user from placing any body part near the blade or compression apparatuses. Hinges have been added to allow access for the user to certain areas of the machine to remove jammed hose during the cutting phase. When these hinges are opened a limit switch will turn the system off to stop operation while the door is opened.

HOW IT WORKS

The Large Hose Cutting Machine uses a drive system with two knurled rollers that measure and drive the hose to the desired length. The hose is driven into a compression system, where the blade cuts to give a clean, perpendicular edge finish.

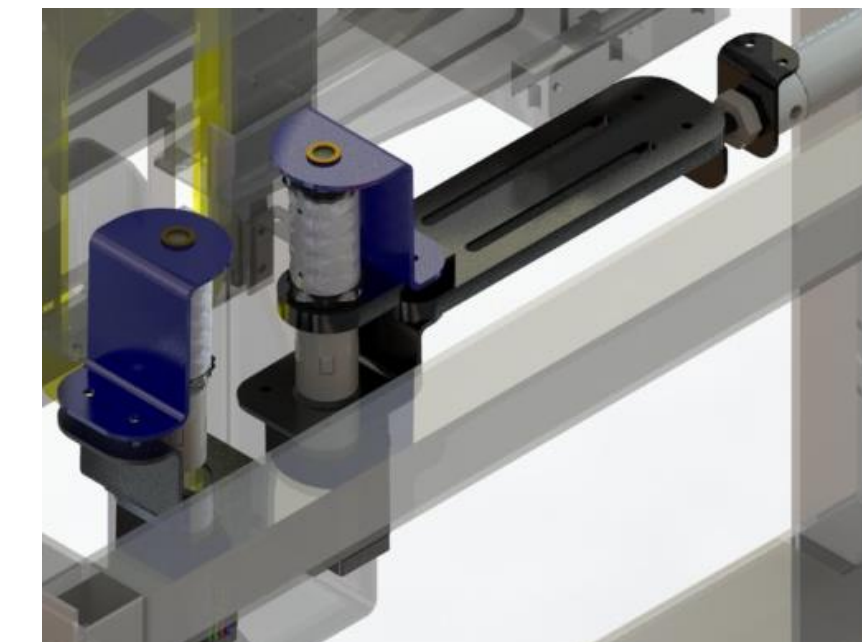

Project Implementation

The Large Hose Cutting Machine will reduce time for each cut, as well as reduce debris and deformity, and prevent stress on the hands of employees. This machine will be used in the TFI warehouse to cut multiple diameter hose, and can be adapted to a variety of different hoses they may implement in the future.

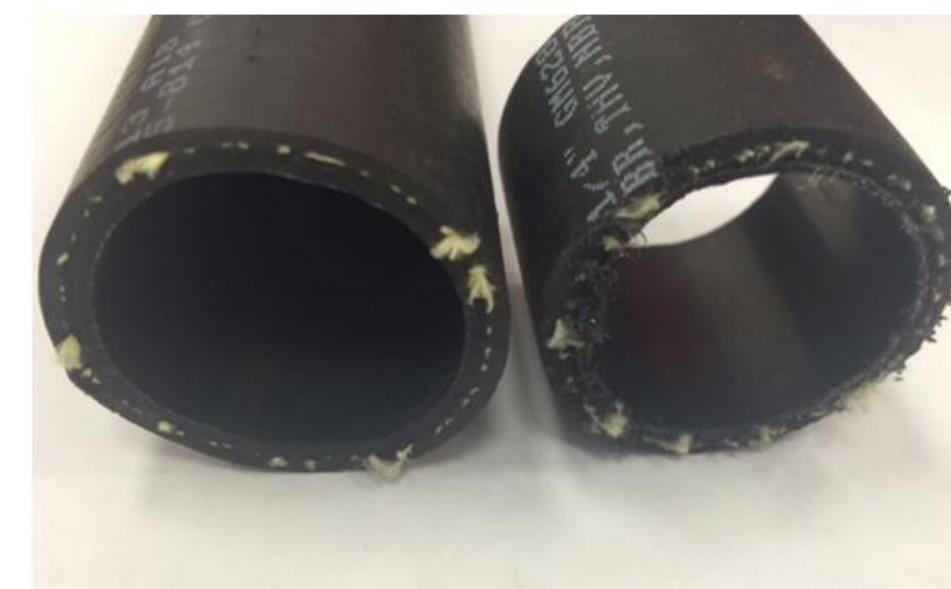

Cut Comparison

The Large Hose Cutting Machine's (left) vs. TFI's current method of cutting hose (right).

Drive System

The drive system uses two knurled rollers that are attached to two stepper motors and increment the hose to the desired length. One roller is permanently fixed about its axis, while a second roller is attached to a sliding mechanism that is controlled by a pneumatic actuator. This mechanism applies force on the hose to achieve driving with automation, and accommodates all specified diameter hoses.

Cutting and Compression Mechanism

The cutting mechanism is straddled by two sets of plates that will compress the hose for a straight cut. A max gap of 0.75" is required between plates, and the hose must be compressed to 1/2" for accurate cuts. The blade is attached to a holder that is driven by a 4.5" actuator mounted underneath the table. Simulated tests were conducted resulting in measured force of approximately 1000 lbs. that is necessary to cut through all types of hose.

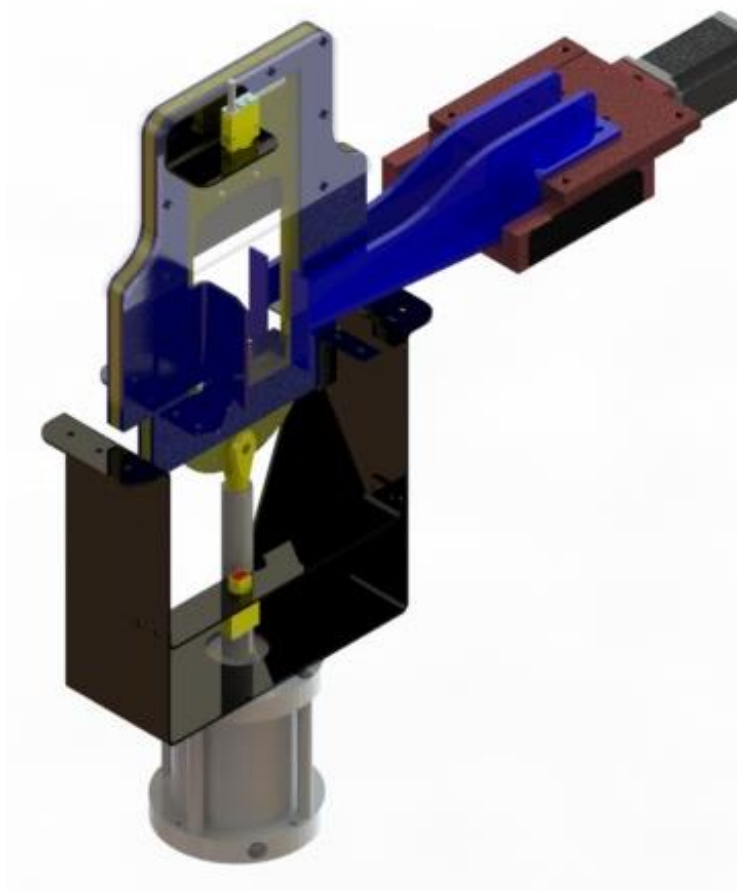

Blade and Off-the Shelf Components

The Large Hose Cutting Machine is designed to work with many off-the-shelf components. The motors, blade, and actuators can be bought and replaced on the machine directly from packaging. The blade is an inexpensive replacement scraper blade available at many hardware stores

