

Standards for Working Drawings

27 August 2013

Department of Mechanical and Mechatronic Engineering and Sustainable Manufacturing
California State University, Chico
Chico, California 95929-0789

Contents

1	Scope	4
2	Assembly and Subassembly Drawings	4
	2.1 Function of an Assembly Drawing	4
	2.2 Subassemblies	4
	2.3 Views	5
	2.4 Hidden Lines	5
	2.5 Dimensions	5
	2.6 Item Numbers	5
3	Detail Drawings	6
	3.1 Function	6
	3.2 Views	6
4	Bill of Materials	6
	4.1 Contents	6
	4.2 Location	7
	4.3 Standard Format	7
5	Drawing Numbers	7
6	Drawing Sheets	8
	6.1 Sizes	8
	6.2 Order	8
	6.3 Binding	9
7	Title Blocks	9
	7.1 Location and Contents	9
	7.2 Arrangement	10
	7.3 Drawing Template	10
8	Revision Blocks	10
	8.1 Location and Content	10
	8.2 Standard Format	10
9	Dimensioning	11
	9.1 Units	11
	9.2 Tolerances	11
	9.3 Leading Zeroes	11
	9.4 Completeness	11
10	Notes	11

Appendix – Example of a Set of Working Drawings	12
1. Toggle Clamp (Assembly Drawing)	13
2. Handle (Sub-Assembly Drawing)	14
3. Link (Detail Drawing)	15
4. Base (Detail Drawing)	16
5. Hold-down Arm (Detail Drawing)	17
6. Handle-half (Detail Drawing)	18

1 Scope

This standard defines guidelines for constructing a set of working drawings, i.e., production drawings, for a product. A set of **working drawings** contains all the information needed to manufacture a product. It includes all the information needed to fabricate each part, specify all standard components, and assemble the parts and standard components into the product.

In this standard, a **part** is an object fabricated from a single piece of material and for which a detail drawing is included in the set of working drawings. A **standard component** in this drawing standard is an unaltered component for which no detail drawing is included because the part is to be procured from a source which fabricates that component to that source's specifications.

The three components of a set of working drawings are:

1. Detail drawings of each part to be fabricated
2. Bill of materials
3. Assembly (and if applicable subassembly) drawings

An example of a set of working drawings for a toggle clamp appears in the Appendix.

The guidelines in this standard take precedence over those in the American National Standard Engineering Drawing and Related Documentation Practices (ASME Y14/ANSI Y14). Documentation practices in ASME Y14/ANSI Y14 shall be followed if those practices are not addressed in this document.

2 Assembly and Subassembly Drawings

2.1 Function of an Assembly Drawing

An assembly drawing shows how a collection of parts, standard components, and subassemblies fit together into a finished product. Every set of working drawings should include at least one assembly drawing. If the product includes multiple entities which are not connected together, then an assembly drawing for each entity should be included.

2.2 Subassemblies

If an assembly drawing would be cluttered or unclear if all parts and standard components were shown on it, then one or more subassembly drawings should be included which show how subsets of the product's parts and standard components are assembled. A subassembly can then be drawn on the assembly drawing as one unit without showing the details of all the parts and standard components which are part of

that subassembly. Unlike an assembly drawing, a subassembly drawing does not show a finished product.

2.3 Views

Assembly and subassembly drawings should show the parts, standard components, and subassemblies in their true positions relative to one another. They should contain the minimum number of views which clearly show how the parts, standard components, and subassemblies are put together. The view(s) shown may be one of the following:

1. Parallel or perpendicular to a main surface or plane of the assembly or subassembly
2. Isometric
3. A combination of the above isometric and parallel or perpendicular to a main surface or plane of the assembly or subassembly

Orthographic views should be shown in third angle projection.

For clarity, an exploded view may also be included when the assembly or subassembly has concealed parts or is otherwise complicated.

2.4 Hidden Lines

Assembly and subassembly drawings generally should not include hidden lines which do not clarify how the product is assembled. Thus, absence of a hidden line does not imply that no hidden edge exists at that location.

2.5 Dimensions

Generally, the only dimensions shown on assembly and subassembly drawings are those needed to assemble the parts, standard components, and subassemblies. Thus, dimensions needed solely to fabricate a part should not be shown on assembly or subassembly drawings.

Properly dimension features in the view that is most appropriate. Dimensions should not be repeated in different views. Chain dimensioning is encouraged. Multiple features of a dimension should include a multiplier for replications. For example, four holes with diameter dimension of 10 mm should be listed on one hole as 4X10Ø. If the angle of an arc is greater than 180° then use diameter symbol. For arcs with angles less than 180° use the R symbol.

Dimensions should be placed outside the part area. Place dimensions in the center of arrows. Dimension lines should not cross. Extension lines should not connect to drawing lines but they can cross them.

2.6 Item Numbers

A single instance of each unique part, standard component, or subassembly is identified with an item number on an assembly or subassembly drawing. Only in rare cases when it would be extremely difficult to determine the location of a second or subsequent instance of a unique part, standard component, or subassembly should the second or subsequent instance be identified with the already existing item number.

Item numbers should appear in circular balloons which should be drawn well outside the perimeter of the assembly or subassembly. The balloons should be numbered sequentially in a clockwise fashion with the balloon with number 1 in the top center location of the drawing, e.g., at the 12-o'clock position. They should appear around the periphery of the assembly or subassembly with the item numbers in numerical order as the periphery is traversed. Each balloon should be connected to the item to which it refers with a leader line which terminates with an arrowhead touching the edge of the item or a dot on the surface of the item. Leader lines should not cross one another and the number of times they cross other lines should be minimized. If an exploded view is present, the item numbers should appear only on that view. Examples of an assembly drawing and a subassembly drawing are in the Appendix.

3 Detail Drawings

3.1 Function

A detail drawing is a drawing of a part which provides all the information needed to fabricate the part. This includes the part's shape, dimensions, material, and any special requirements, e.g., surface finish or heat treatment.

3.2 Views

Normally at least three orthographic views (front, top, and right side) should be shown as well as an isometric view. Orthographic views are shown in third angle projection. Examples of detail drawings are in the Appendix.

4 Bill of Materials

4.1 Contents

A bill of materials for an assembly or subassembly is a tabular listing of all the parts, standard components, and subassemblies in the assembly or subassembly. At a minimum, a bill of materials should include:

1. Item numbers (which appear in balloons with leader lines to item)
2. Descriptions (words which describe the part or subassembly)
3. Drawing numbers or part numbers

- For a part, the drawing number of the associated detail drawing
 - For a subassembly, the drawing number of the associated subassembly drawing
 - For a standard component, the vendor's part number, if it exists
4. Vendor information (for components to be purchased and which are not commonly available)
 5. Quantities required in the assembly (or subassembly)

Entries should appear in numerical order by item number with the lowest number at the top of the list.

Typically, the bill of materials for the parts, standard components, and subassemblies included on an assembly drawing will be printed on that assembly drawing. Similarly, parts, standard components, and subassemblies on a subassembly drawing will be included in the bill of materials on that subassembly drawing.

4.2 Location

When a bill of materials is on an assembly or subassembly drawing, it should be placed in one of the following locations:

1. Upper-left corner of the drawing sheet touching the top and left border lines
2. Lower-left corner of the drawing sheet touching the left and bottom border lines
3. Above the title block touching the right border line and the title block
4. To the left of the title block touching the bottom border line and the title block

The location chosen should maximize the usable space for the drawing of the assembly or subassembly.

4.3 Standard Format

A Department of Mechanical and Mechatronic Engineering and Sustainable Manufacturing SolidWorks standard format bill of materials is available.

All lettering should be in uppercase Arial font.

All drawings and models are designed with ANSI standards and not ISO standards.

Examples are shown on the assembly and subassembly drawings in the Appendix.

5 Drawing Numbers

Each drawing should have a unique drawing number using the format

ccc-ss-tyy-a-dx

(100-02-F13-L1-P1)

where each letter is a placeholder for letters or numerals defined as:

- ccc: Three numeral course number (no suffixes included)
- ss: Two numeral section number
- t: Term (single capital letter: F for fall or S for spring)
- yy: Last two digits of year
- a: Assignment identifier specified by instructor (one or more uppercase Arial font alphanumeric characters)
- d: Drawing type (single uppercase Arial font letter: A for assembly drawing or S for subassembly drawing or P for part drawing or B for bill of materials if bill of materials is on a separate sheet)
- x: Unique identifier consisting of one or more uppercase Arial font alphanumeric characters

When a drawing consists of more than one sheet, each sheet should have the same drawing number, but a unique sheet number.

6 Drawing Sheets

6.1 Sizes

Normally all drawings should be on either size A or size B sheets with border lines and margins as specified in Table 1.

Table 1: Standard Drawing Sheet Sizes

Size Designation	Size of sheet (in)		Margins (mm)	
	Vertical	Horizontal	Top/bottom	Sides
A	8.5	11	10	6
B	11.0	17.0	10	16

6.2 Order

The sheets in a set of working drawings should be assembled in the following order:

1. Assembly drawings
2. Subassembly drawings (if present)
3. Bill of materials (if not included on assembly and subassembly drawing sheets)
4. Detail drawings

The drawings within a category should be ordered by drawing number.

6.3 Binding

Size A sheets should have their top sides on the binding edge of an 8½ x11 inch document. Size B sheets should have their left sides on the binding edge of an 8½x11 inch document and be folded as in Fig. 1.

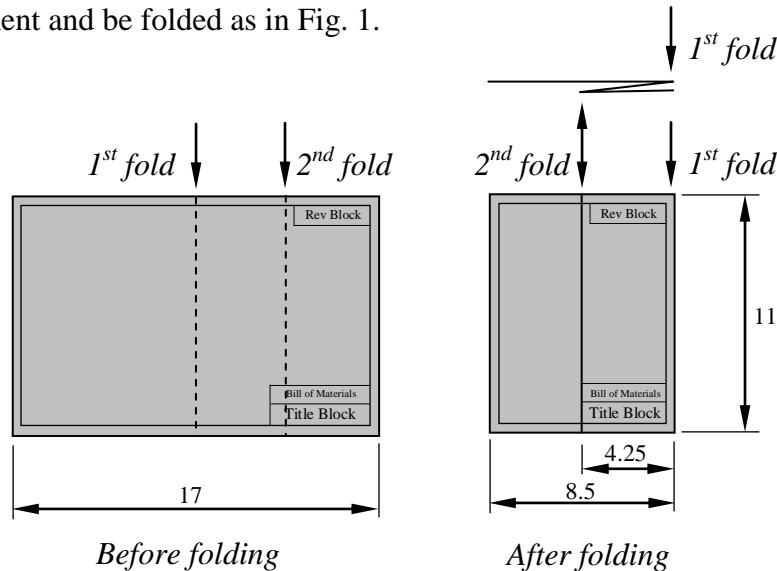

Figure 1: Folding size B sheets (dimensions in inches)

7 Title Blocks

7.1 Location and Contents

A title block should be included on all sheets in the lower right corner. At a minimum a title block should include sub-blocks for:

1. Drawing title (should be descriptive and unique)
2. Drawing number (see Section 5)
3. Revision letter (see Section 8)
4. Department and University names (Mechanical and Mechatronic Engineering and Sustainable Manufacturing; California State University, Chico)
5. Names of following people (first and last name)
 - a. Drawer
 - b. Drawing checker
 - c. Engineering approver
 - d. Manufacturing approver
 - e. Quality assurance checker
6. Dates associated with all names (in format YYMMDD where YY are the last two digits of the year, MM is the two digit number of the month, and DD is the two digit number of the day of the month, e.g., 131108 for 8 November 2013)

7. Predominant scale of drawing (e.g., 1:2)
8. Drawing size letter designation (see Section 6.1)
9. Units used for dimensions and general tolerance note
10. Material (insert N/A on assembly and subassembly drawings)
11. Finish (insert N/A on assembly and subassembly drawings)
12. Third angle projection symbol
13. Sheet number and total number of sheets (e.g., 1 of 2)

All sub-blocks should include the indicated information except perhaps the drawing checker, engineering approver, manufacturing approver, and quality assurance checker boxes and associated date boxes.

Title block lettering should be in uppercase Arial font.

7.2 Arrangement

The information should be arranged as shown in the example drawings in the Appendix.

7.3 Drawing Template

Department of Mechanical and Mechatronic Engineering and Sustainable Manufacturing SolidWorks drawing templates are available for both size A and size B sheets which include borders and a title block.

8 Revision Blocks

8.1 Location and Content

The revision block should be located in the upper right corner of the drawing. The block should include columns for:

1. The zones of the drawing where the revisions have been made
2. Uppercase Arial revision letters
3. Descriptions of changes in uppercase Arial font
4. Names of approvers of changes (first and last name) in uppercase Arial font
5. Dates of approval of the changes (in format YYMMDD)

Space should be reserved to extend the revision block downward as required.

The original drawing has no revision letter and should include a dashed line. The first revision to the original drawing is revision A.

8.2 Standard Format

A Department of Mechanical and Mechatronic Engineering and Sustainable Manufacturing SolidWorks standard format revision block is available.

All lettering should be in uppercase Arial font.

9 Dimensioning

9.1 Units

Le Système International d'Unités (SI) units should be used. The unit of measurement on a drawing should be stated in the tolerance note in the title block and should not appear with the numerical value of each dimension. All dimensions of the same type, e.g., distance, should be in the same unit of measurement.

9.2 Tolerances

All dimensions should have an associated tolerance. A general tolerance note should be included in the title block with exceptions included with the dimension as shown on the example drawings in the Appendix.

Recommended tolerances can be found in Machine Tool Practices. ⁱ

When no other tolerances are specified, the following can be used.

Table 9.2.1 Standard tolerances

1 decimal place (.x)	± 0.2
2 decimal places (.xx)	± 0.01
3 decimal places (.xxx)	± 0.005
4 decimal places (.xxxx)	± 0.0005

9.3 Leading Zeroes

For dimensions less than one unit, a leading zero should appear before the decimal point. For example, the decimal representation of a one quarter millimeter dimension is 0.25 where the mm is omitted because it would appear in the tolerance block.

9.4 Completeness

The drawings should include fully dimensioned three or four views as necessary.

10 Notes

The use of manufacturing and assembly notes on assembly, subassembly, and detail drawings should be avoided whenever possible.

Appendix

Example of a Set of Working Drawings

Figure 2.Toggle Clamp (Assembly Drawing)

Figure 3.Handle (Sub-Assembly Drawing)

Figure 4.Link (Detail Drawing)

Figure 5.Base (Detail Drawing)

Figure 6.Hold-down Arm (Detail Drawing)

Figure 7.Handle-half (Detail Drawing)

Toggle Clamp (Assembly Drawing)

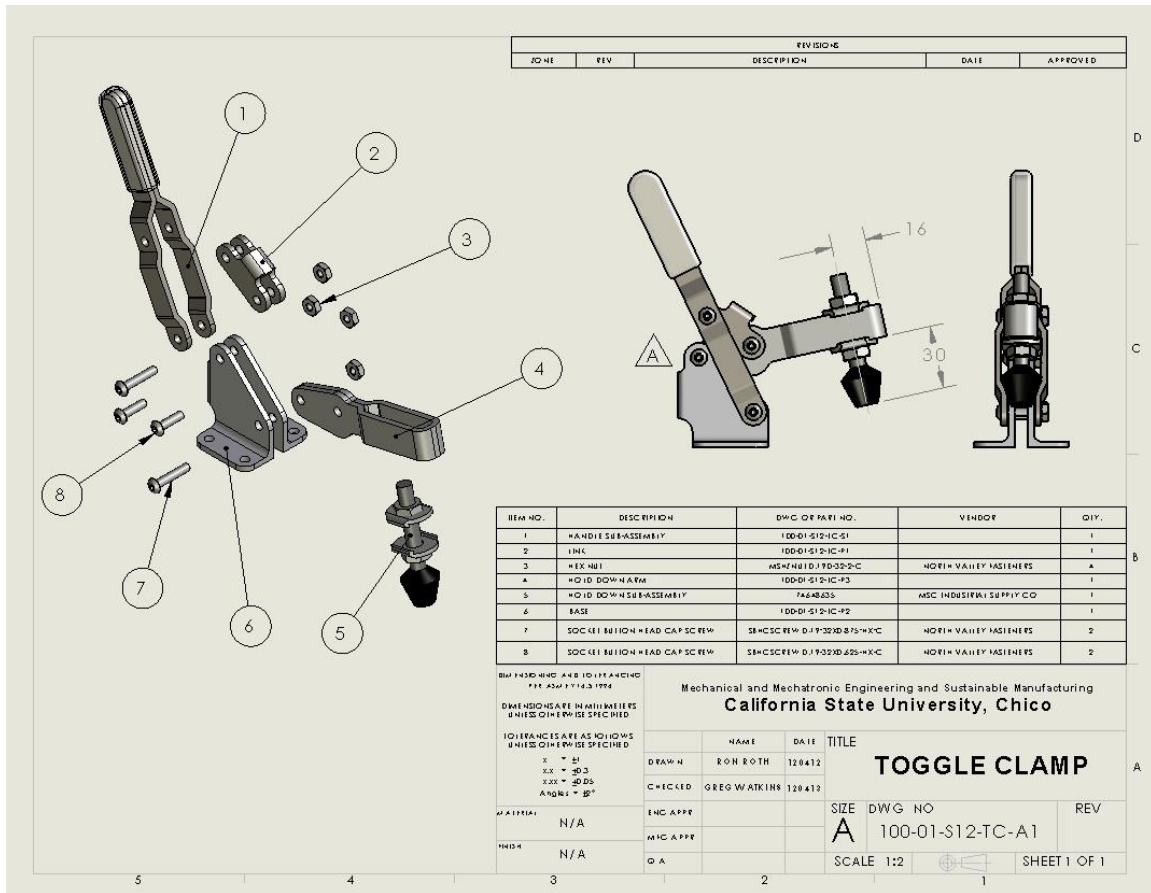

Figure 2: Toggle Clamp (Assembly Drawing)

Handle (Sub-Assembly Drawing)

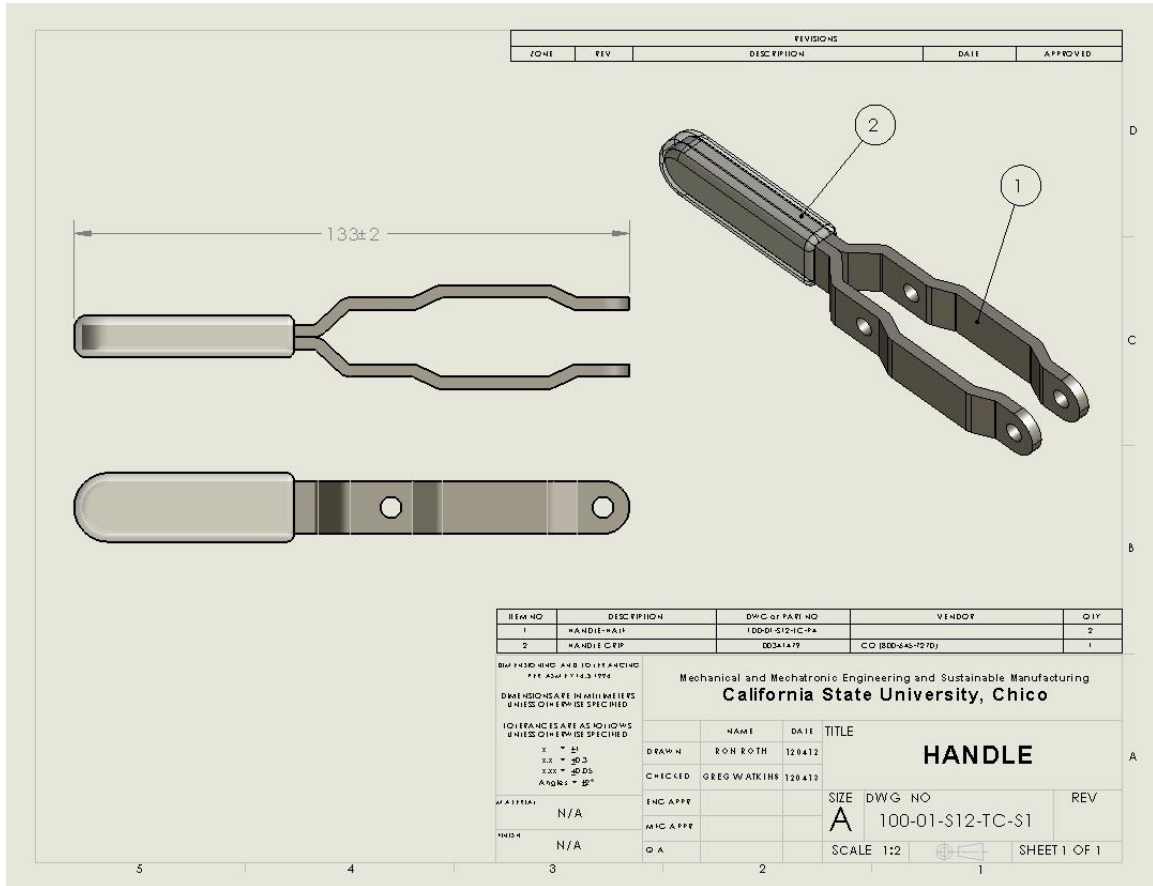

Figure 3: Handle (Assembly Drawing)

Link (Detail Drawing)

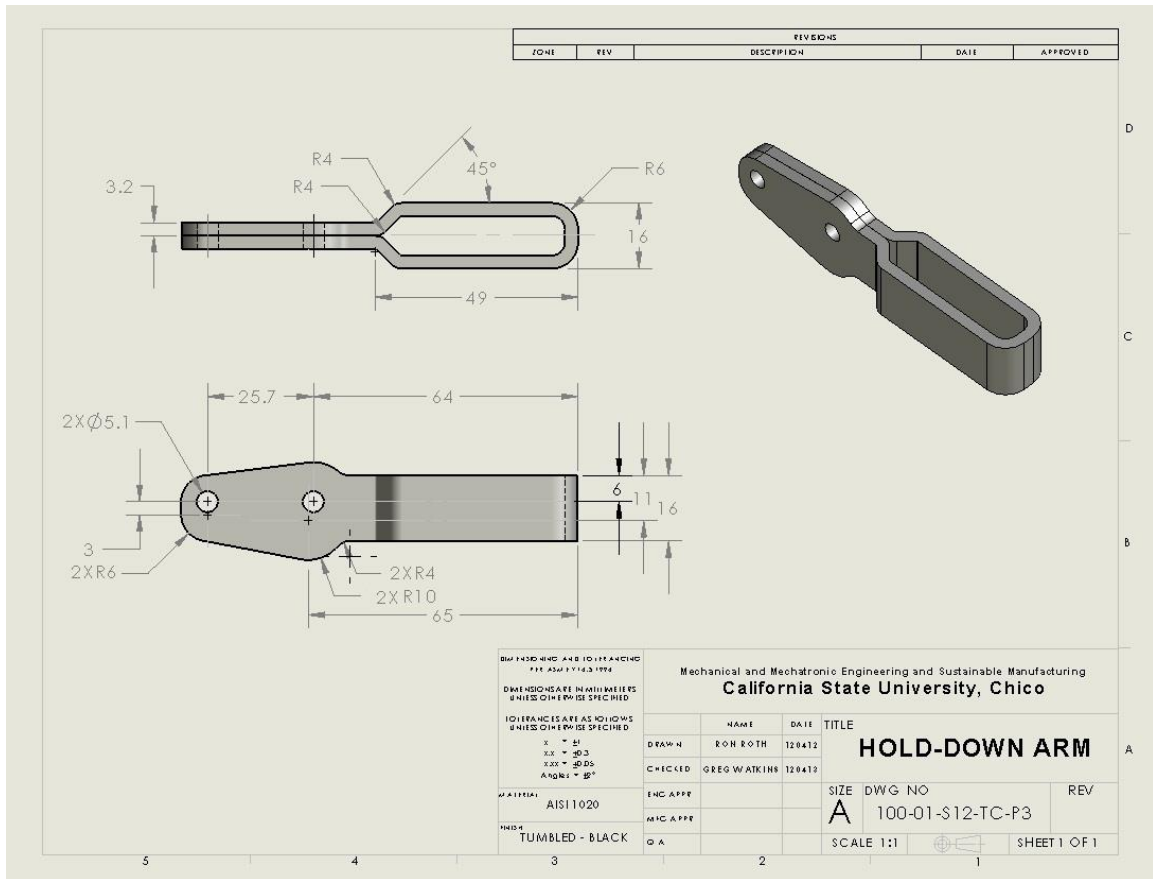

Figure 4: Hold-down arm (Assembly Drawing)

Base (Detail Drawing)

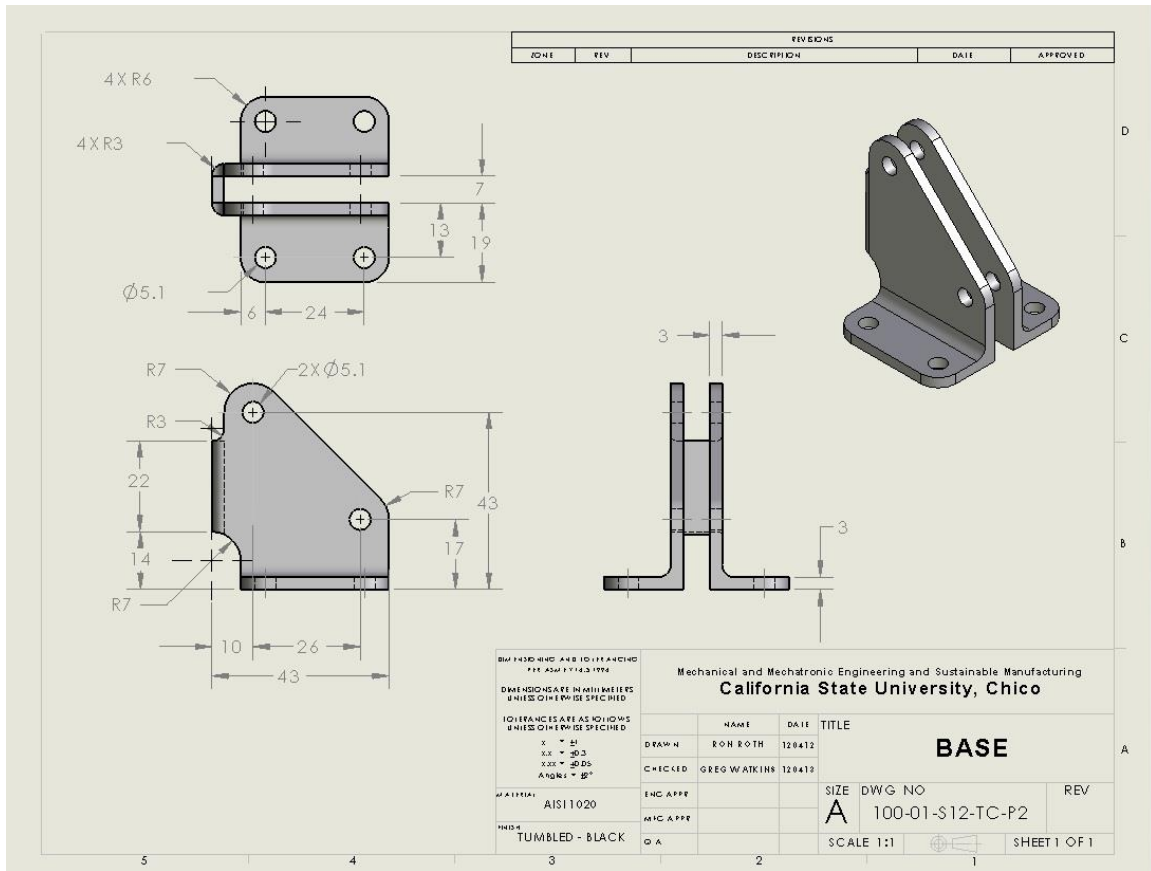

Figure 5: Base (Assembly Drawing)

Hold-down Arm (Detail Drawing)

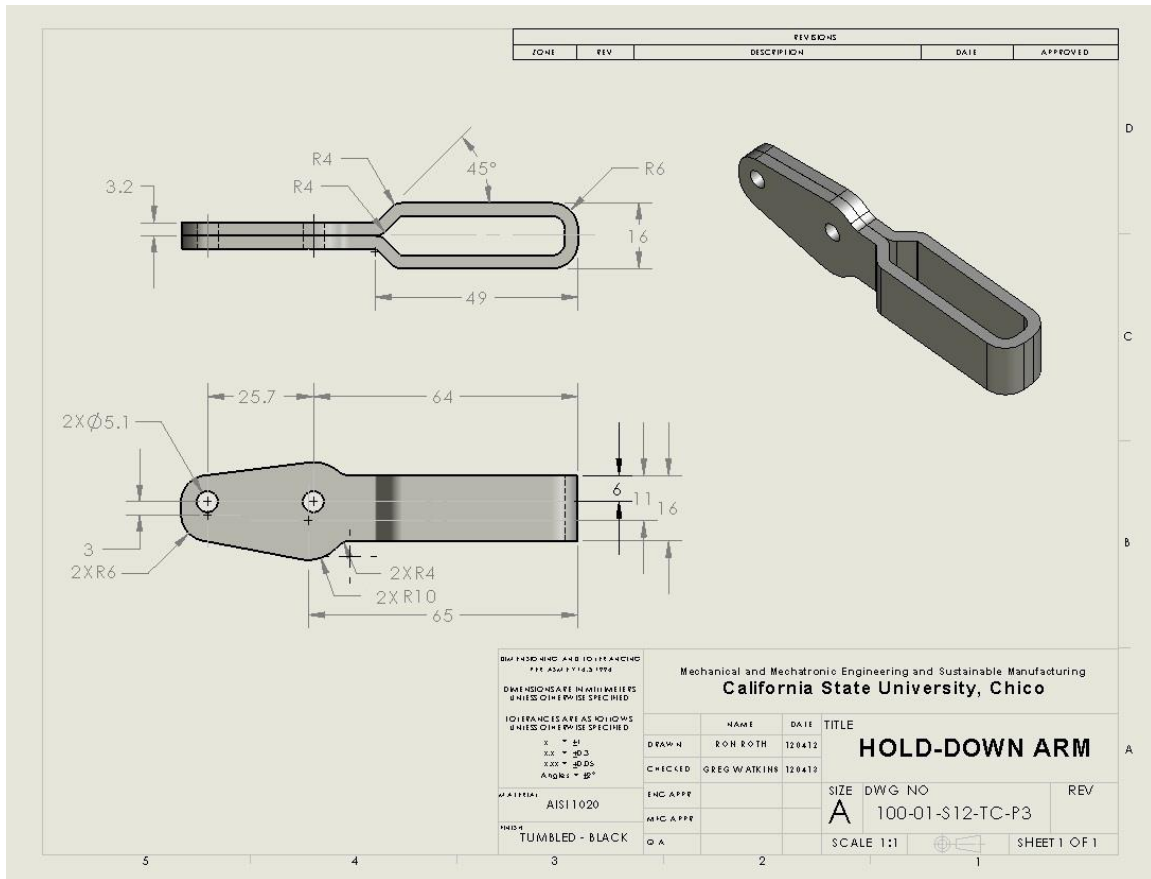

Figure 6: Hold-down arm (Assembly Drawing)

Handle-half (Detail Drawing)

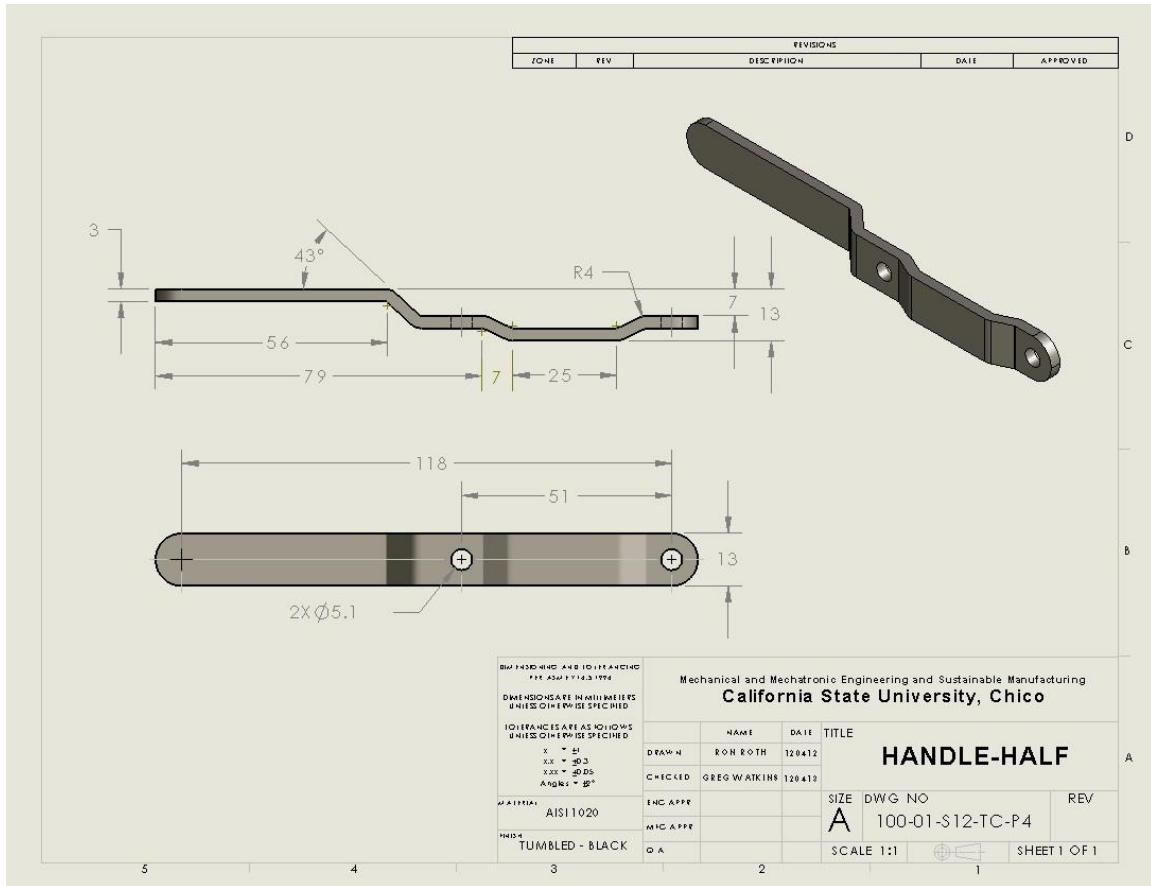

Figure 6: Handle-half (Assembly Drawing)

References

¹ Richard R. Kibbe, John E. Neely, Warren T. White and Roland O. Meyer, Machine Tool Practices (9th edition), (2009) Prentice Hall ISBN-13: 978-0135015087